

STAR-TOFp Safety Review

Dec. 16, 1999, BNL

- Mechanical
- PMT Voltage
- FEE and LV
- Water and Temperature

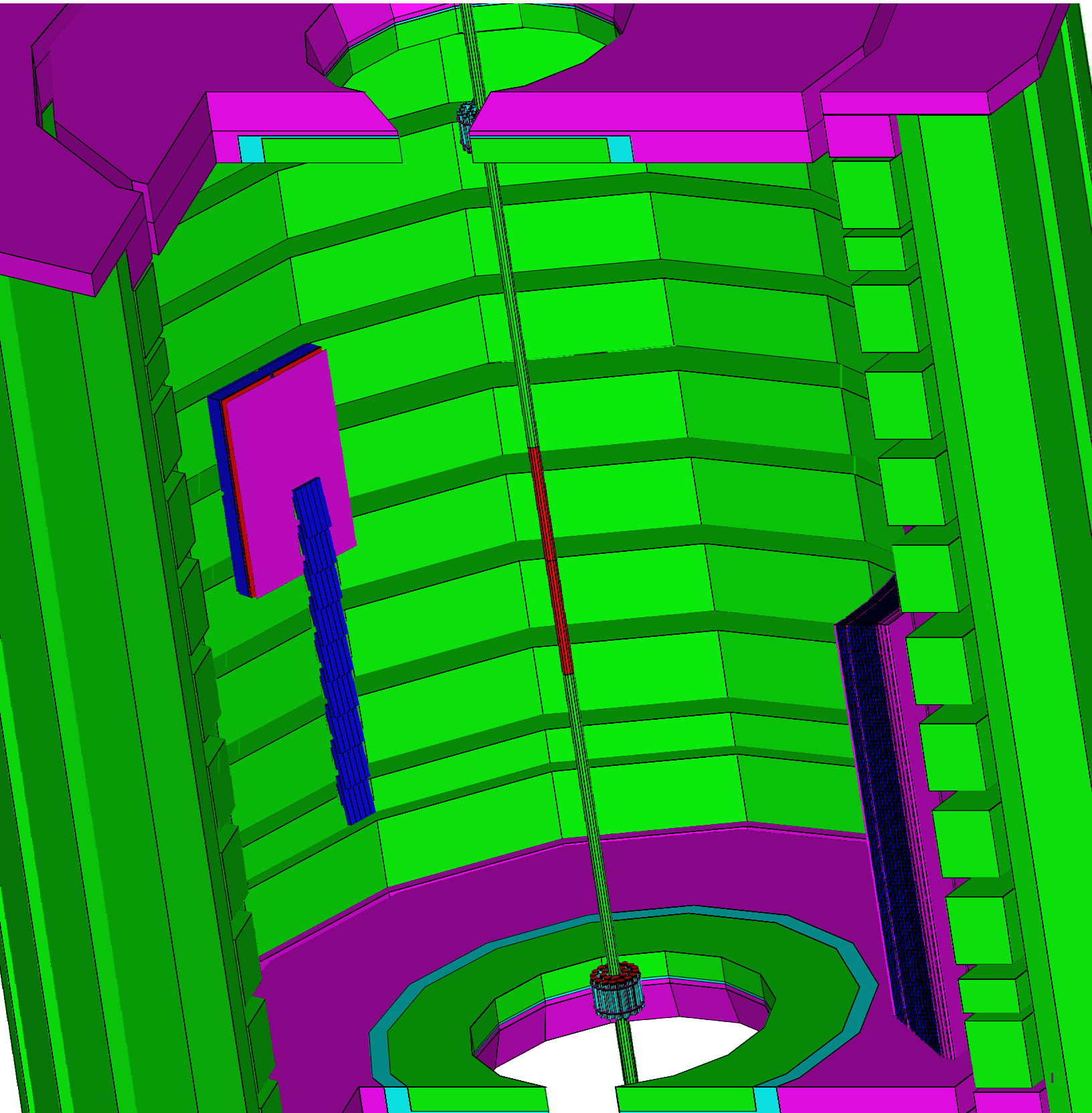

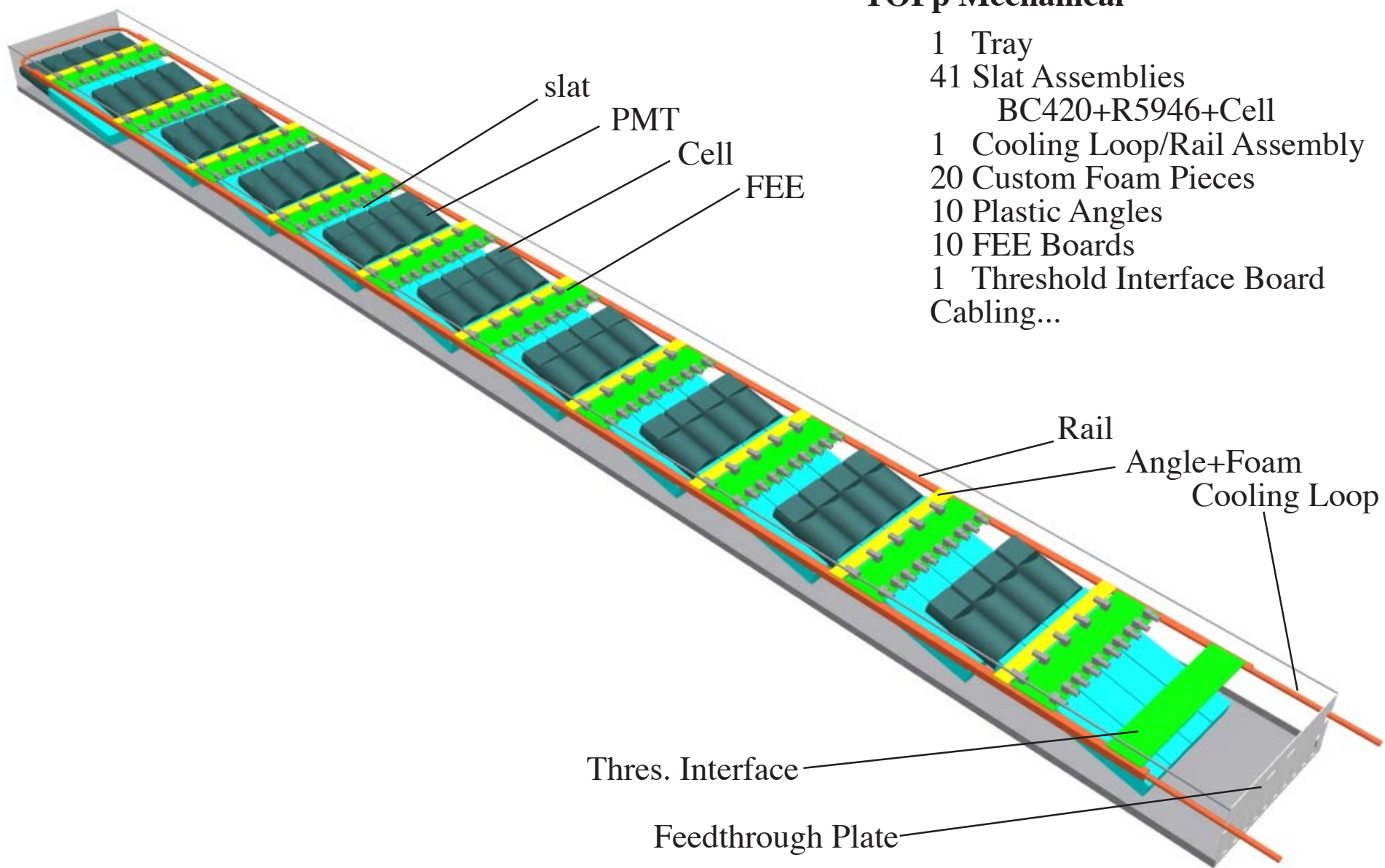

TOFp Mechanical

- 1 Tray
- 41 Slat Assemblies
 - BC420+R5946+Cell
- 1 Cooling Loop/Rail Assembly
- 20 Custom Foam Pieces
- 10 Plastic Angles
- 10 FEE Boards
- 1 Threshold Interface Board
- Cabling...

slat
PMT
Cell
FEE

Rail
Angle+Foam
Cooling Loop

Thres. Interface
Feedthrough Plate

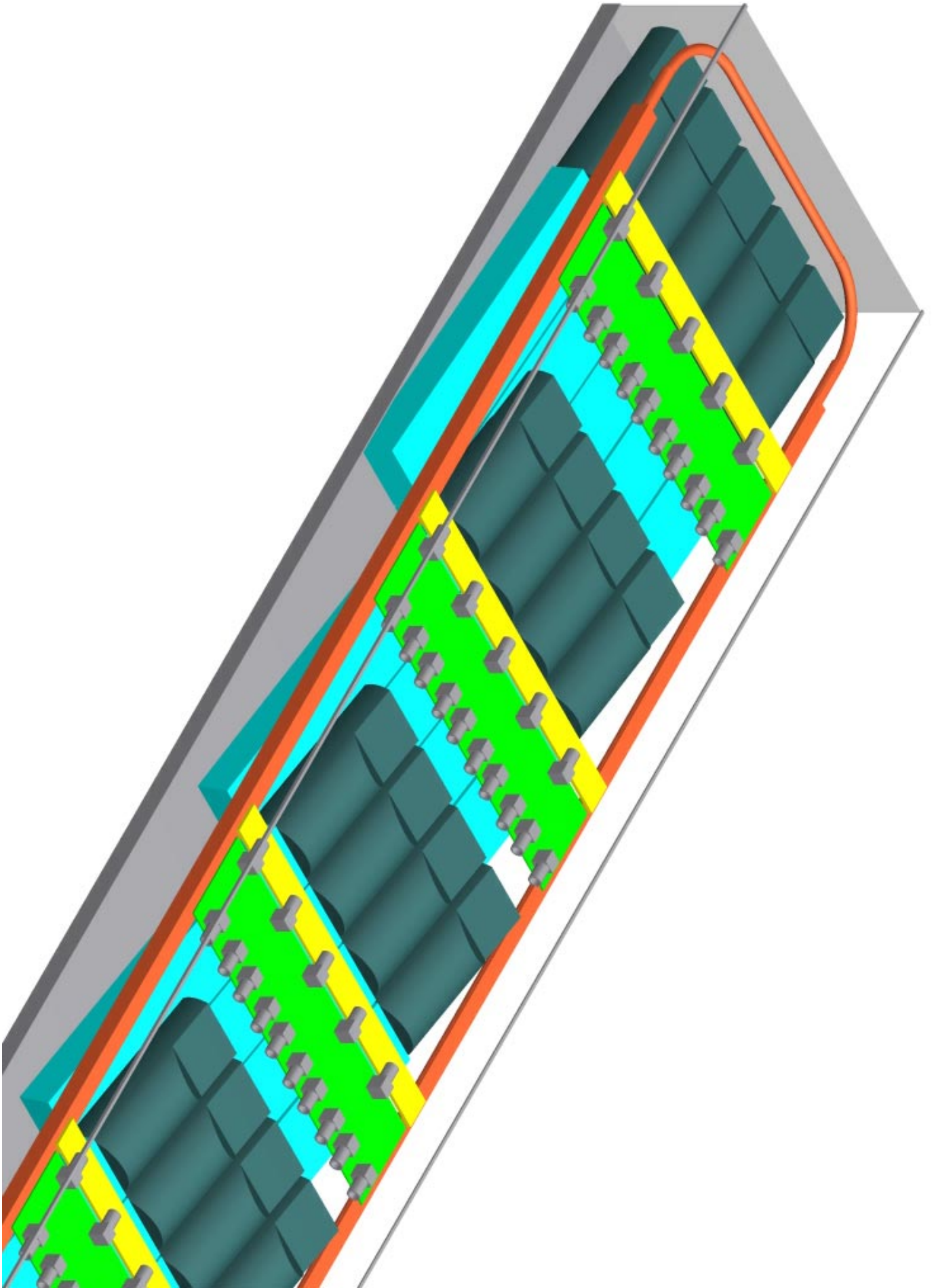

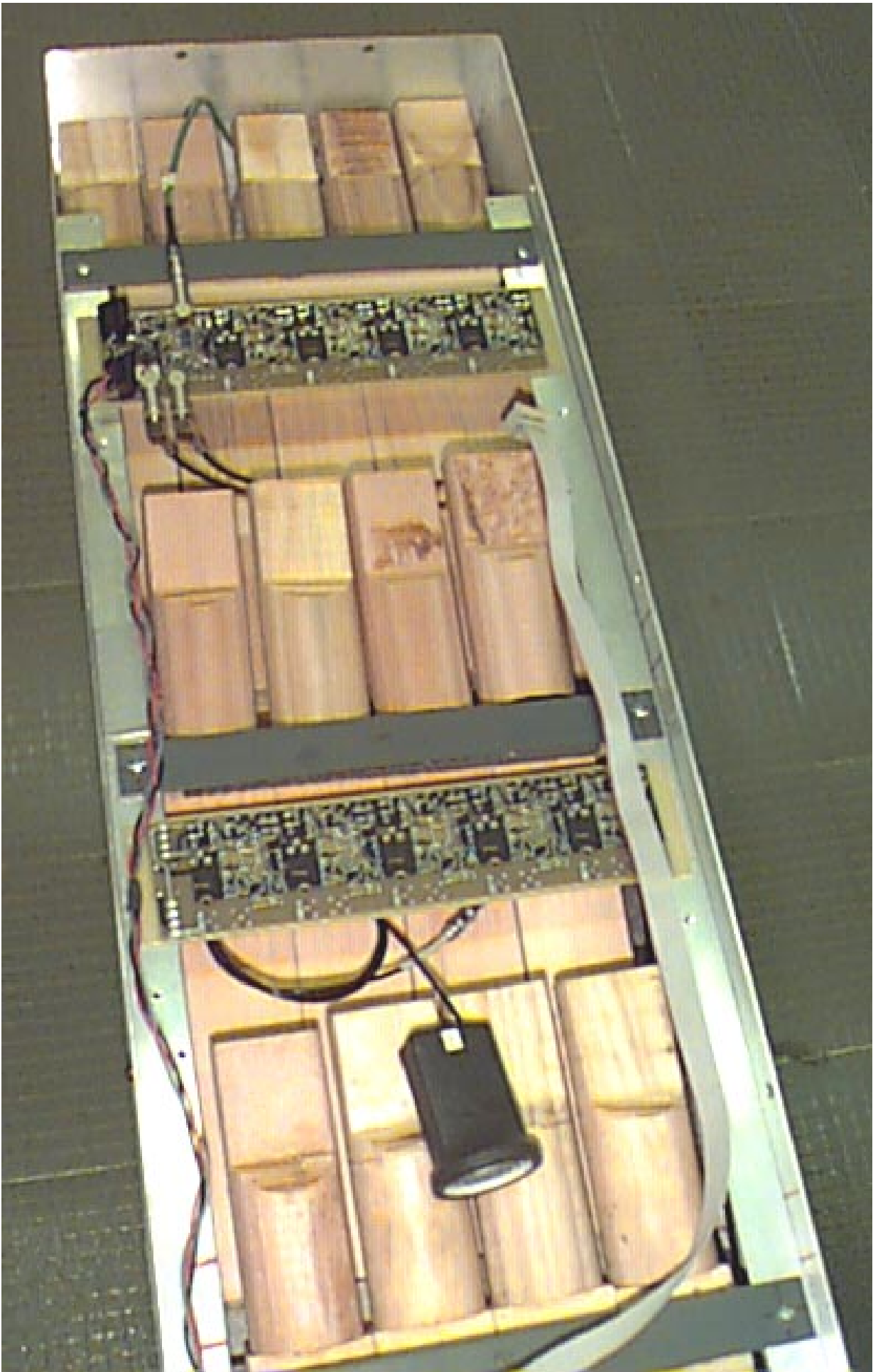

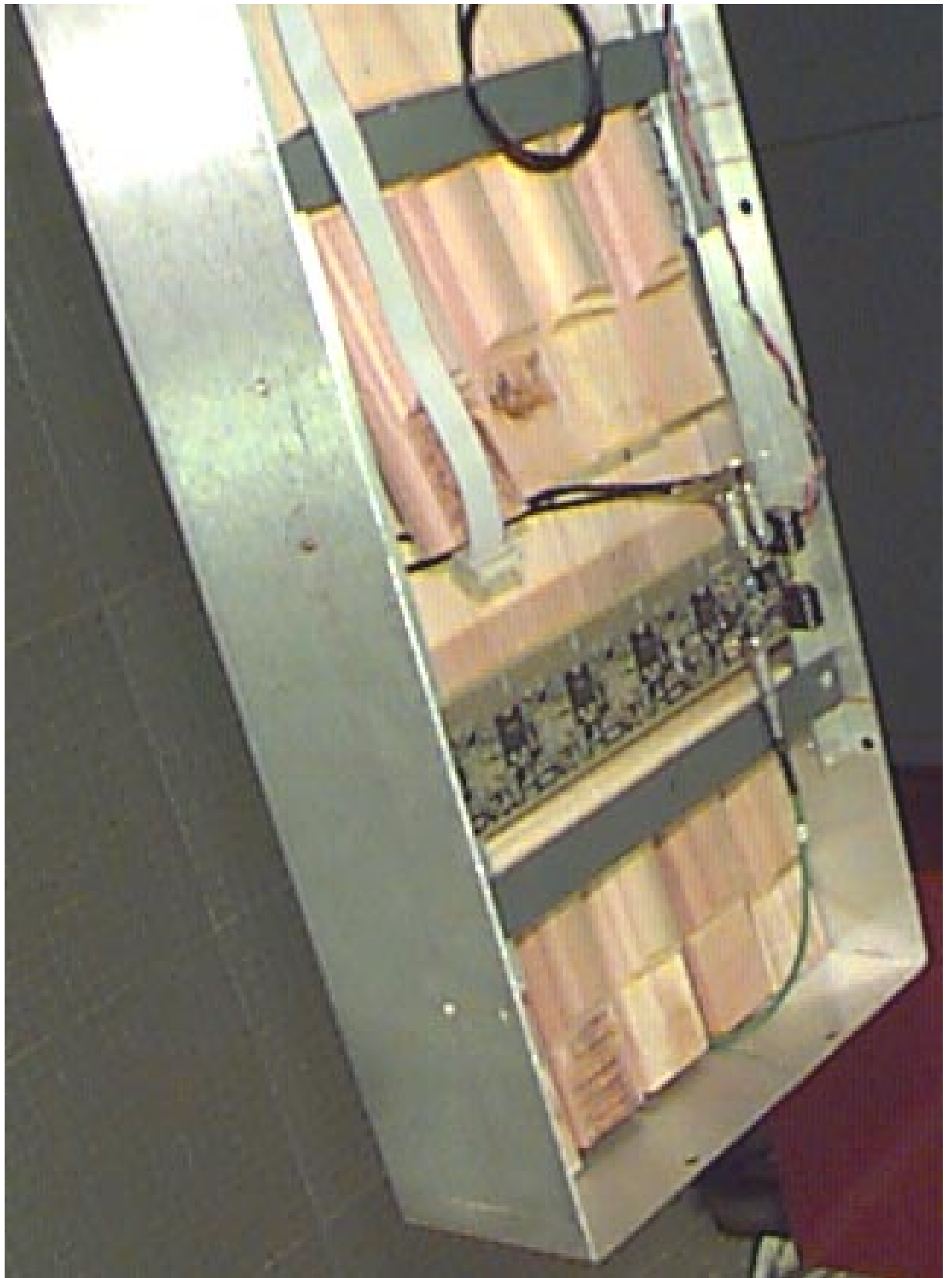

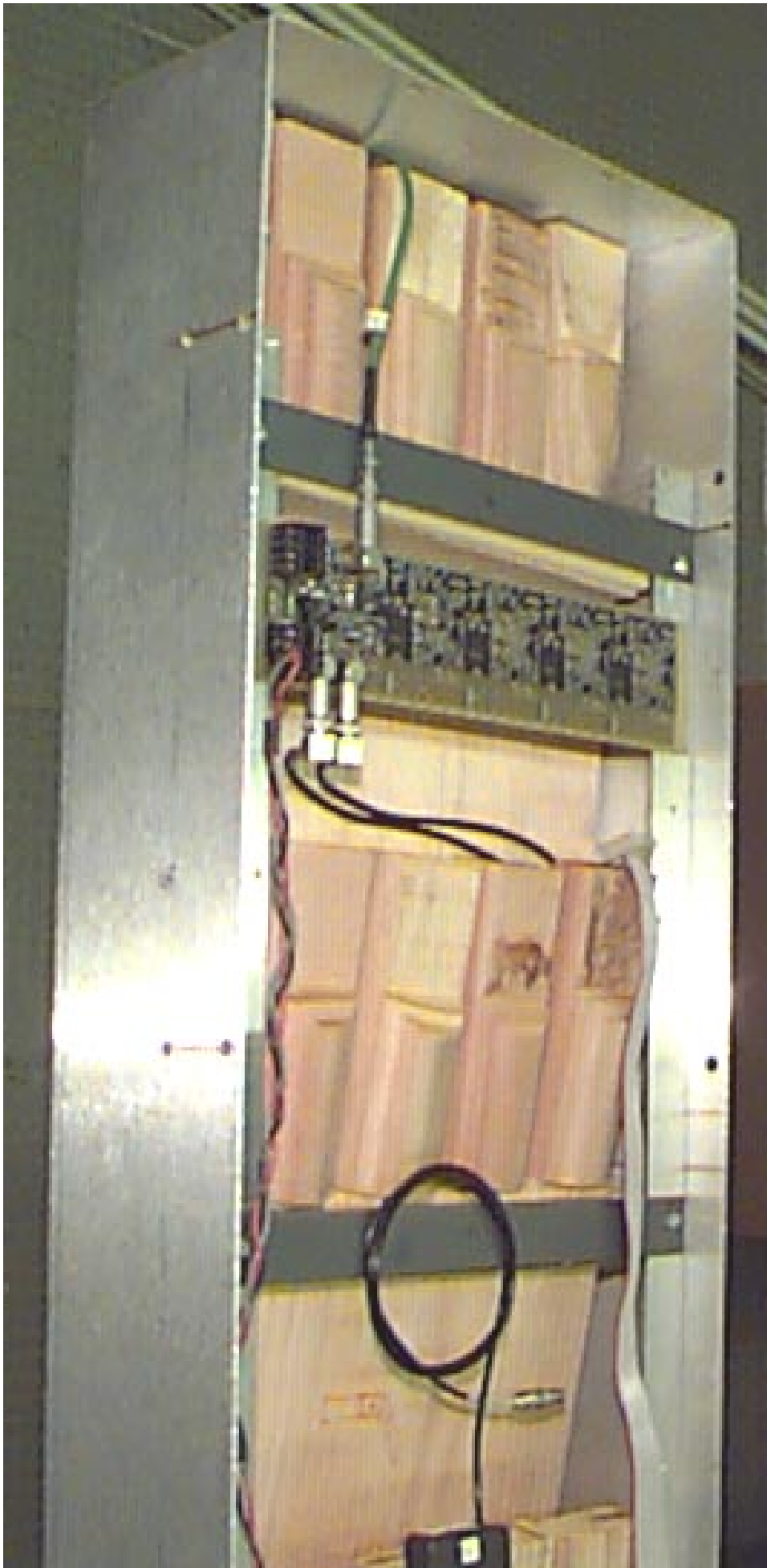

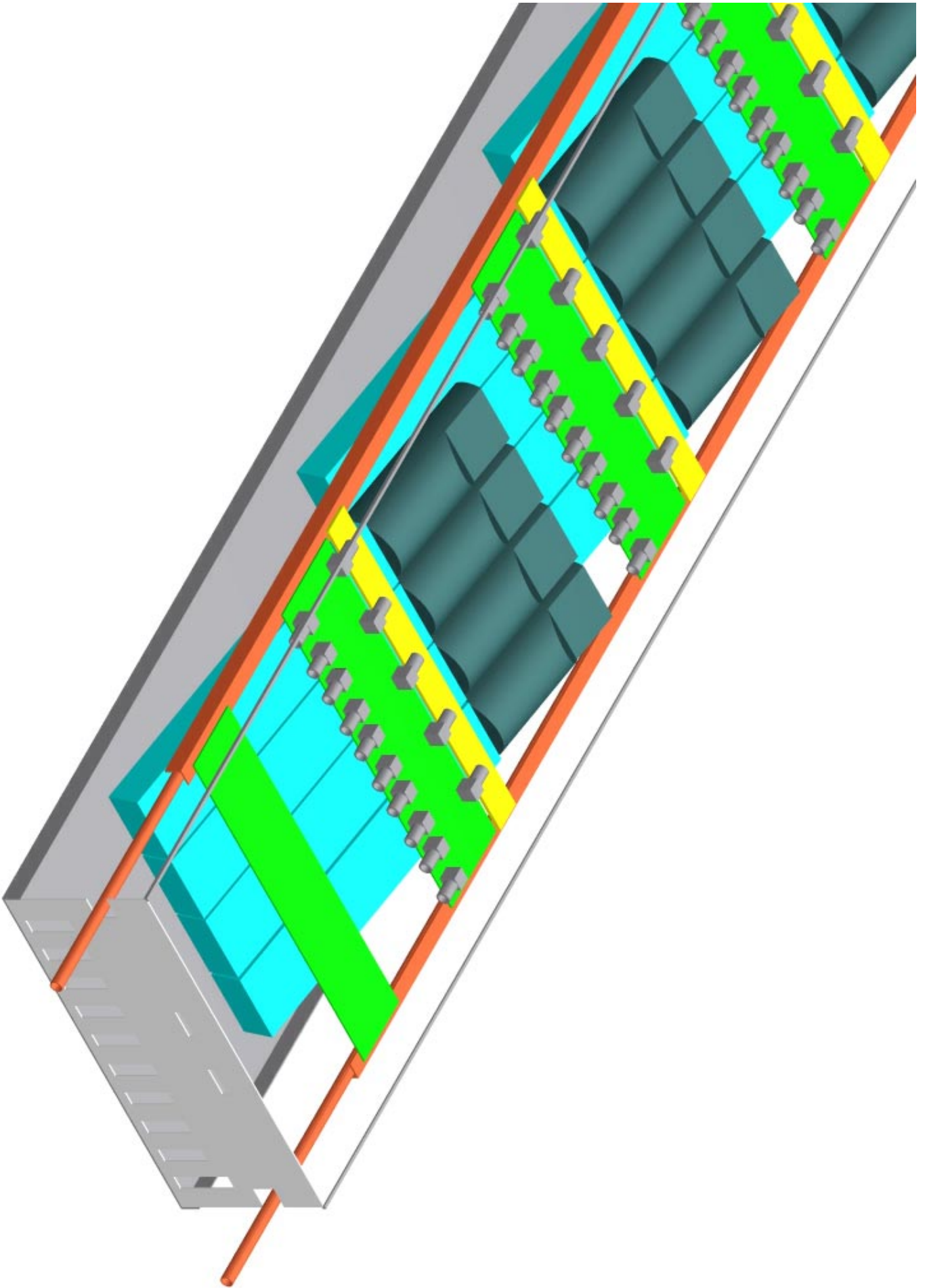



STAR
Standard
Rack

optical fiber
connections to
STAR DAQ &
STAR network.

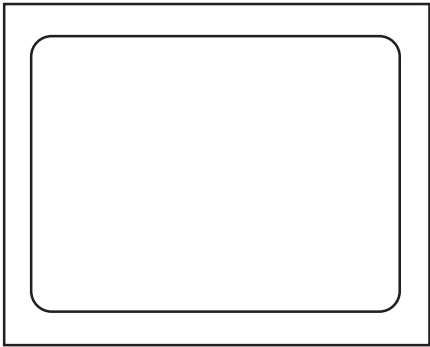

Linux PC

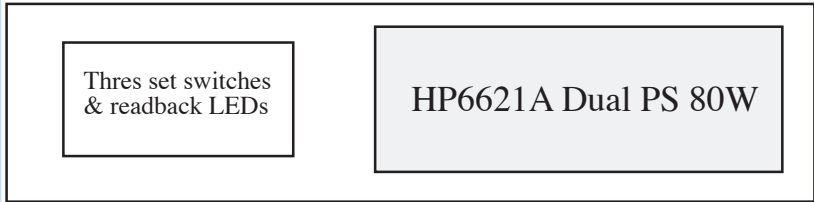

Threshold
Control
Panel

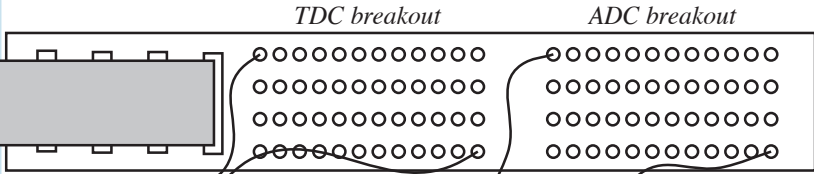

Patch Panel

Signal Cables
from Tray

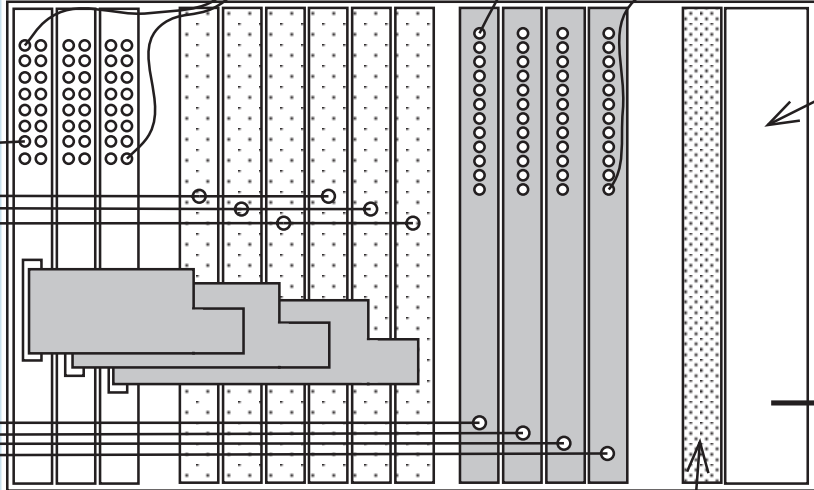

Kinetics 3922
Crate Controller
CAMAC
Crate

cable connection
to Linux PC...

P/S 706
Disc LeCroy
2228A
TDC LeCroy
2249A
ADC I/O Register

TDC starts
& stops

ADC
gates

Start
Signal
(fast path
from pVPD)

Fans, Gate generators, and other NIM logic

NIM bin

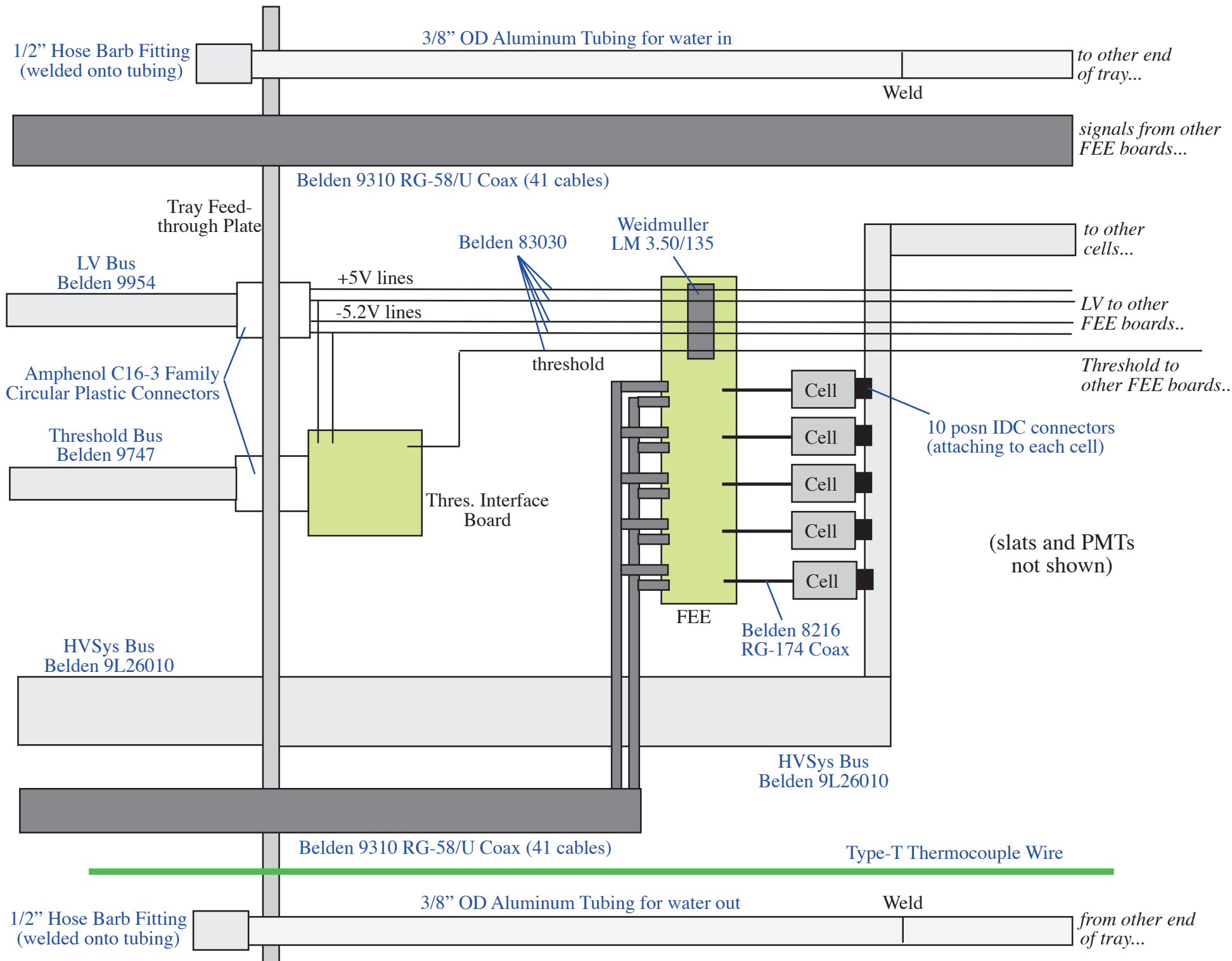

PMT Voltage System

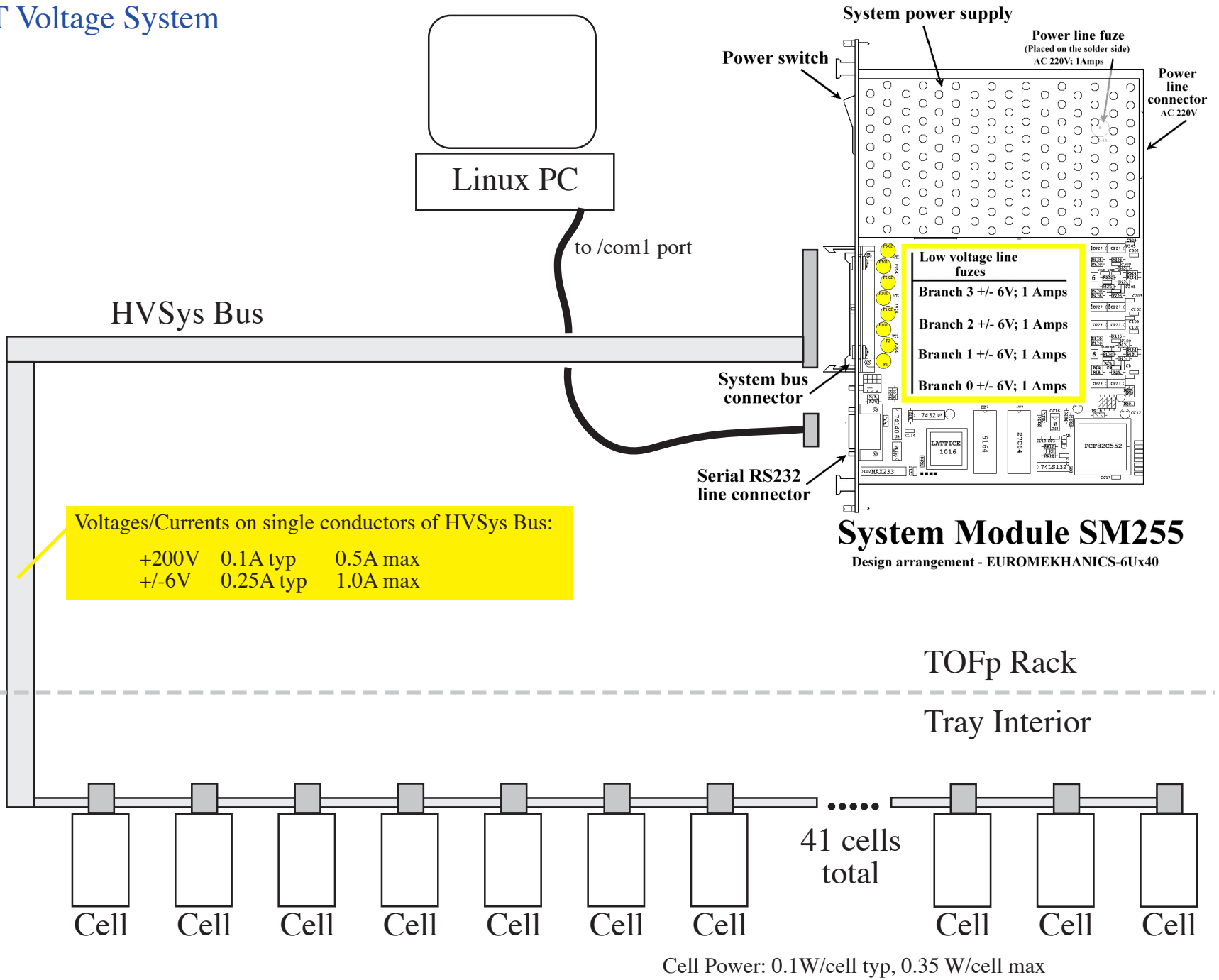

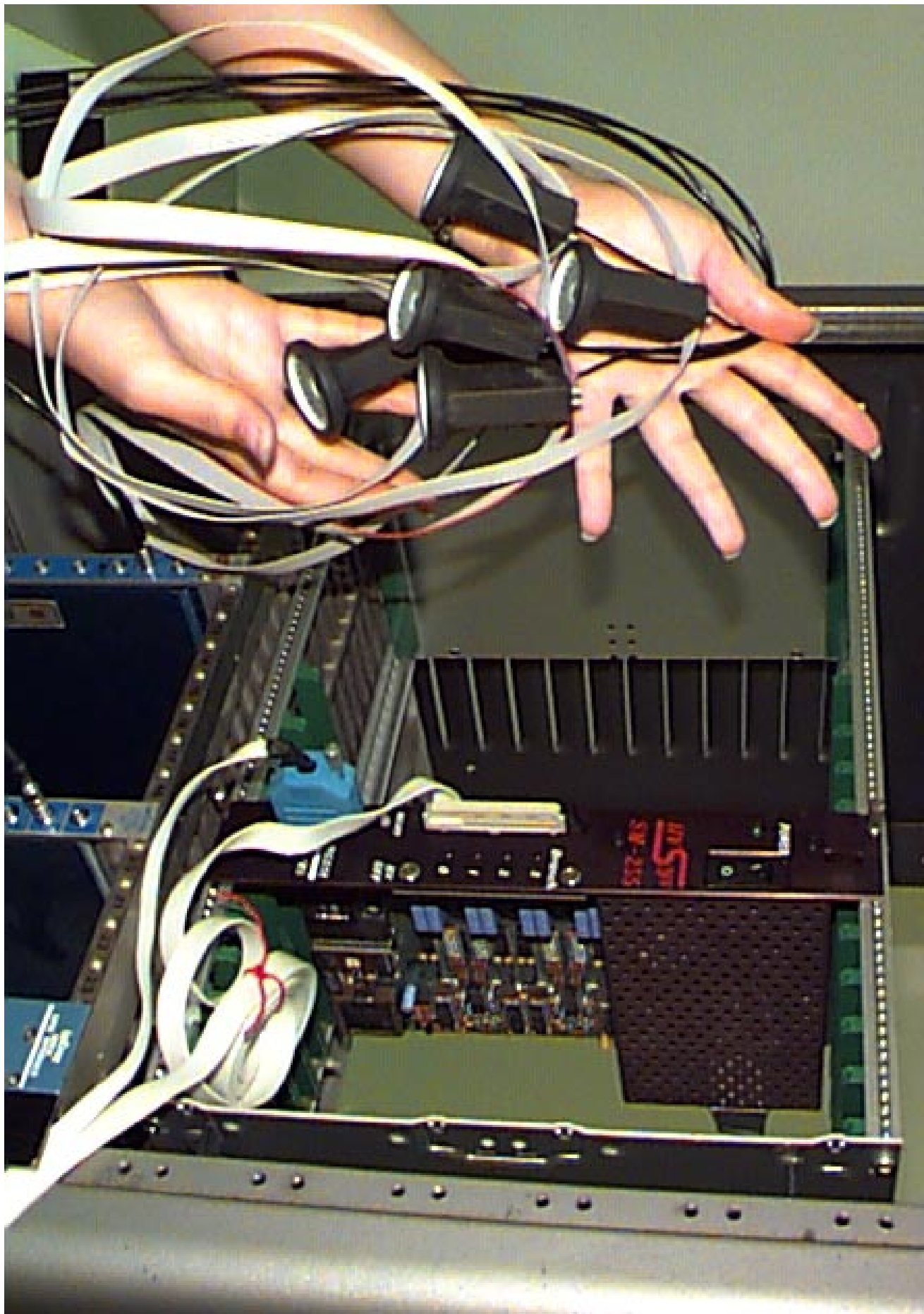

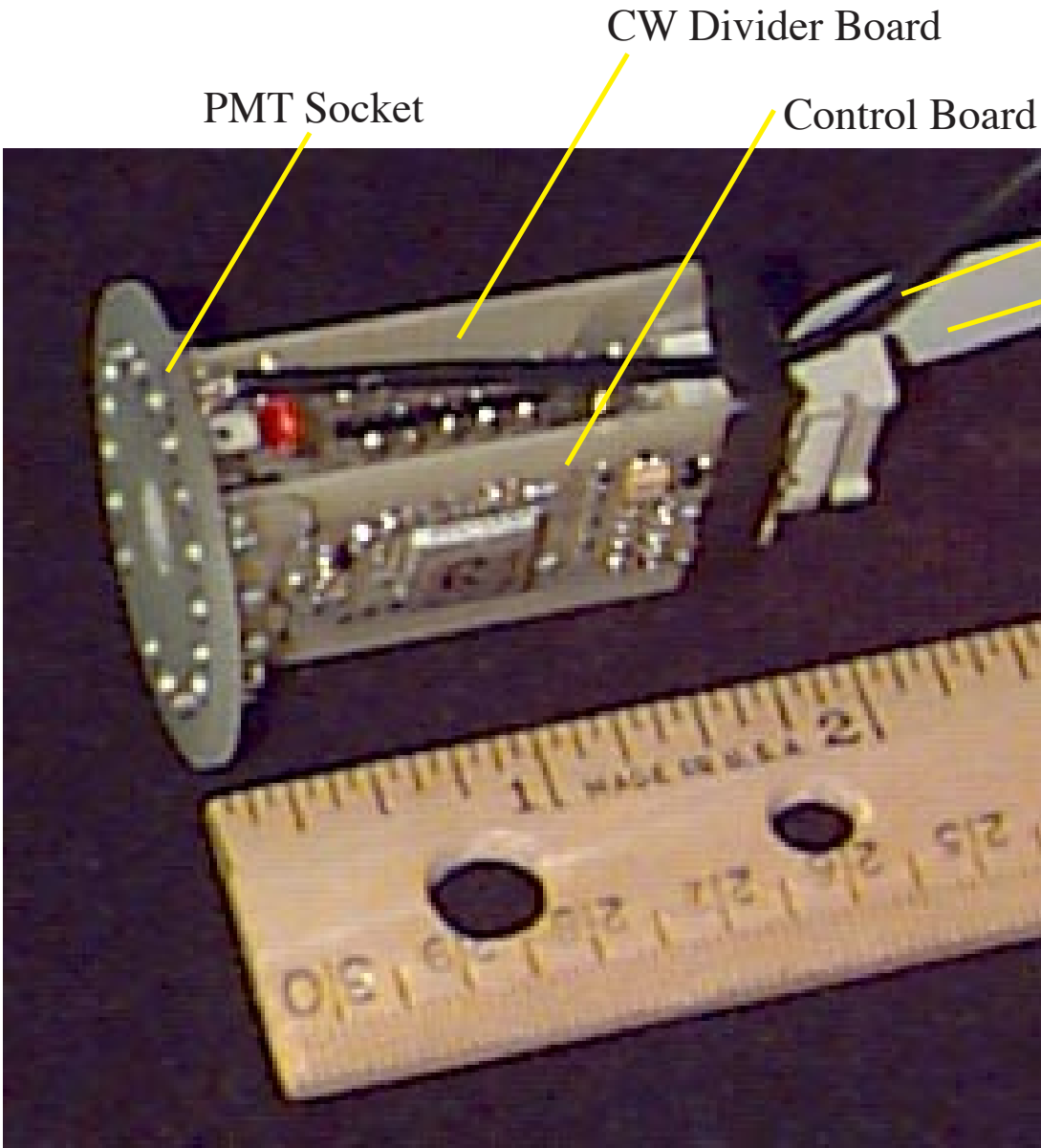

PMT Socket

CW Divider Board

Control Board

PMT Anode signal, RG-174

HVSys Bus

Divider board to be potted with commercial silicon encapsulant

Low Voltage and Threshold System

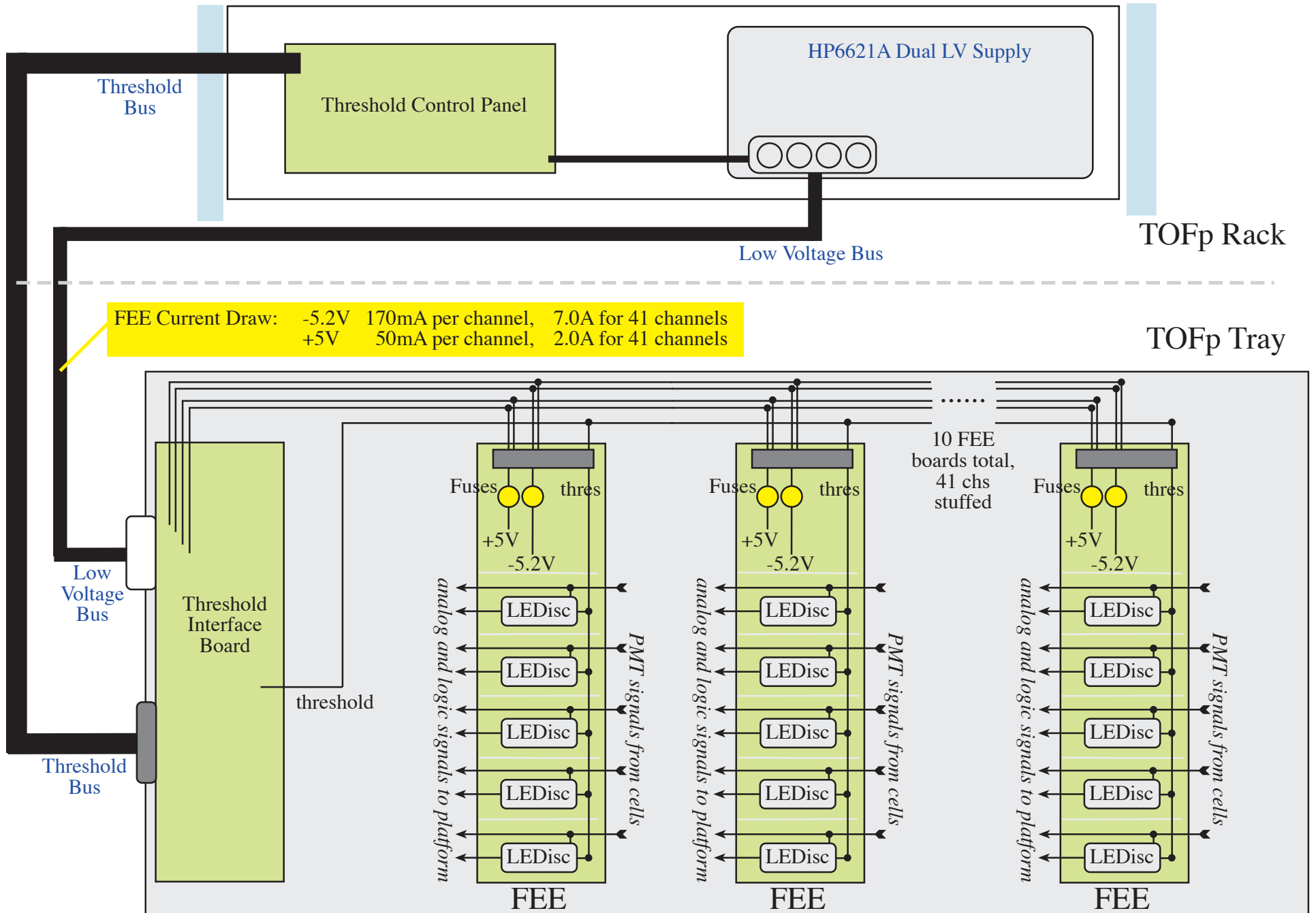

Threshold Control/Readback

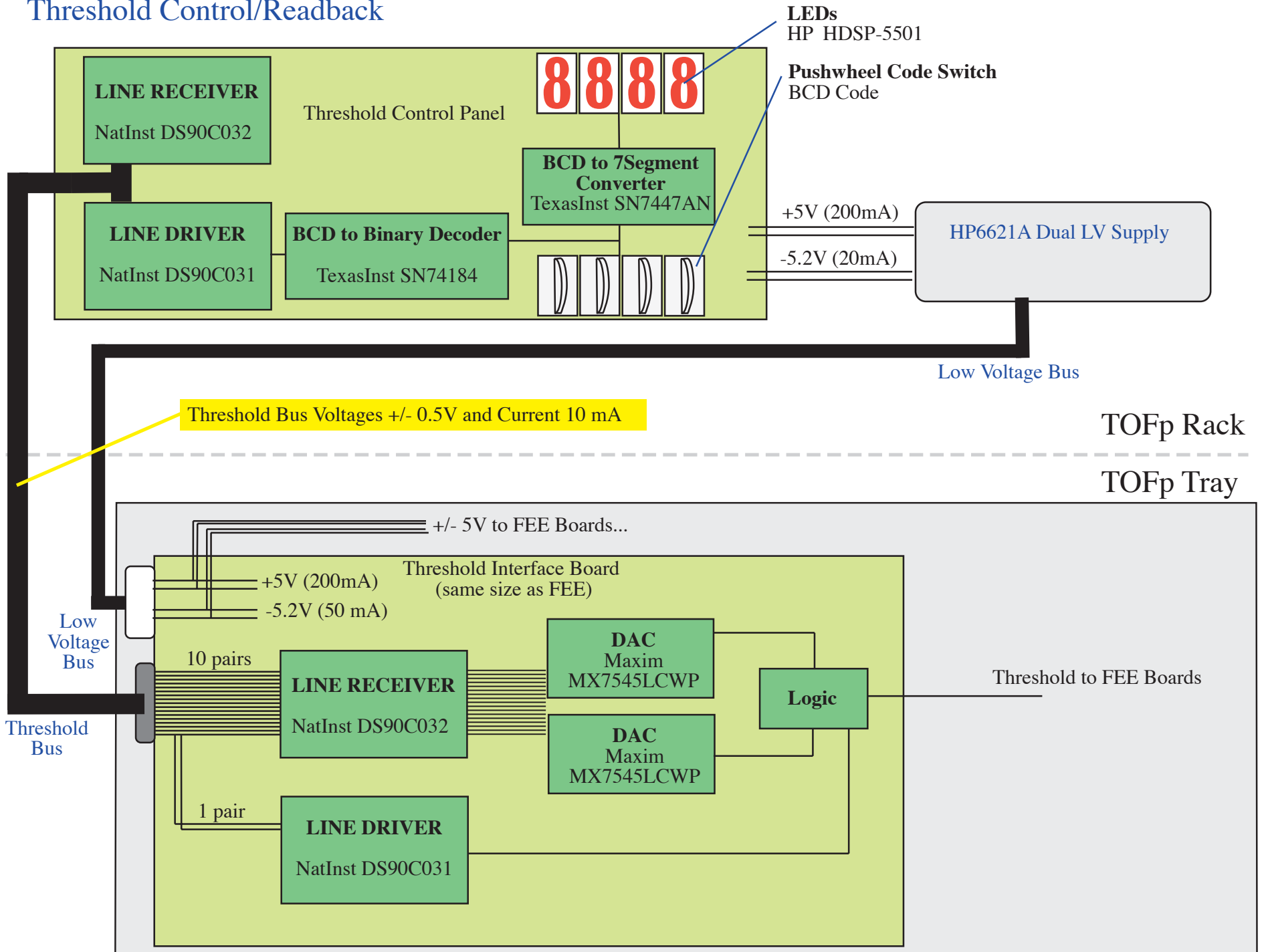

Thermocouple System

TOFp Rack

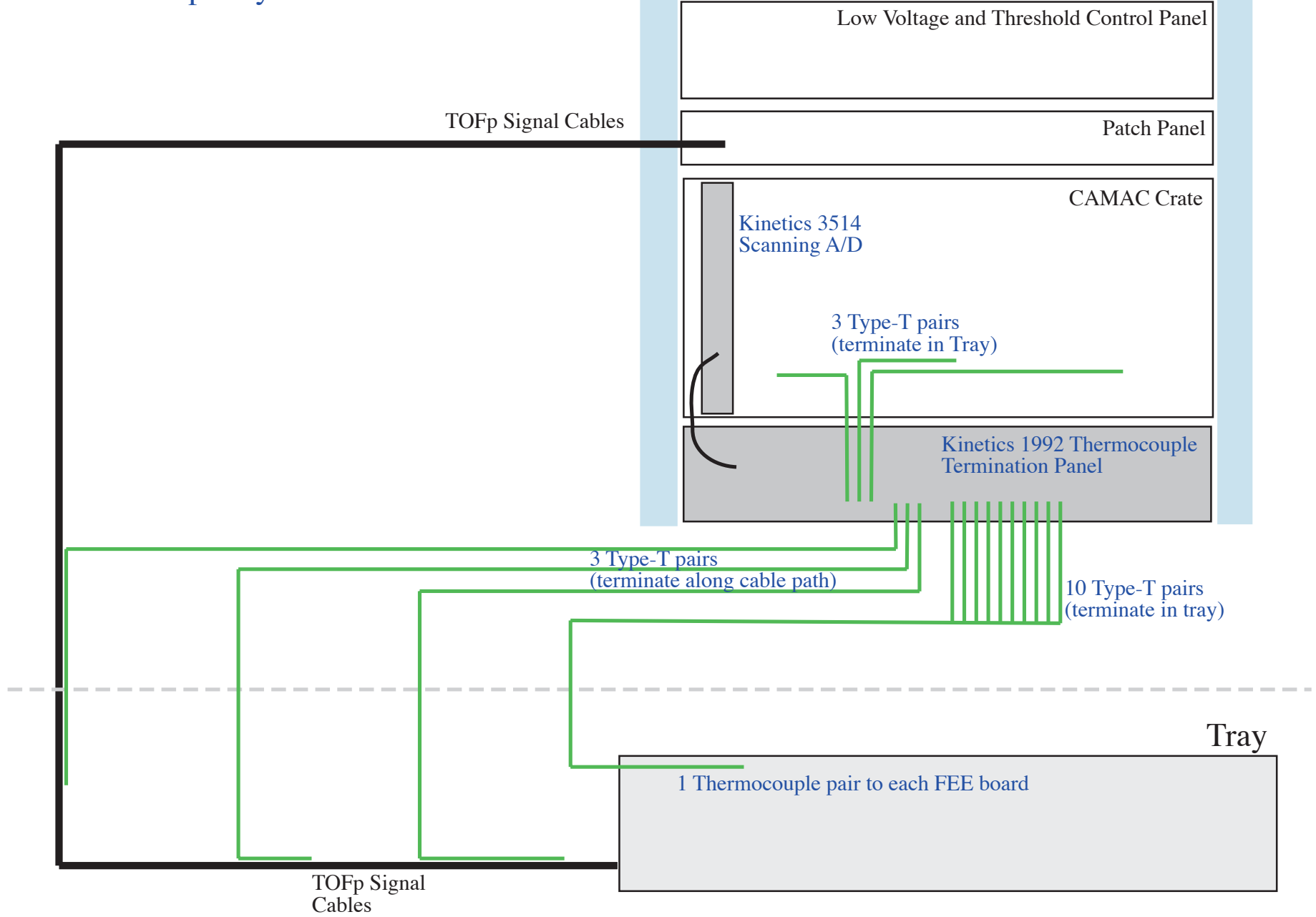

Water System

